

FloorBed Mattress Platform Extension Instruction Manual

IFU-FL1-005EN REV 04

November 2024

Contents

Title	Page
Welcome	2
General warnings	3
1. Safety Instructions	3
2. Intend use	3
3. Technical specification	3
4. Positioning	4
5. Fitting to FloorBed 1 (NSB-0-FL1-200) and FloorBed 2 (NSB-0-FL2-200)	4
6. Fitting to FloorBed 1 USA (NSB-0-FL1-200US)	6
7. Fitting to FloorBed 1-Plus (NSB-0-FL5-100)	8
8. Fitting to FloorBed 1-Plus (NSB-0-FL5-200)	10
9. Fitting to FloorBed 1-Plus USA (NSB-0-FL5-200US)	12
10. Functionality check	14
11. Cleaning and Disinfection	14
12. Storage	14
13. Guarantee	14
14. Disposal	14
15. Contact details	15

Design Policy and Copyright

® And ™ are trademarks belonging to Accora Ltd unless otherwise stated. As our policy is one of continuous improvement, we reserve the right to modify designs without prior notice. © Accora Ltd 2016.

Welcome

Dear Customer,

Thank you for purchasing an Accora healthcare product. We feel sure that this product will exceed your expectations.

This manual is important for realising the full potential of your new FloorBed Mattress Platform Extension; please read it before use. If you need further information, please contact us at:

Tel: 01223 206100

Fax: 01223 206120

E-mail: info@accora.uk.com

This instruction manual applies to the FloorBed Mattress Platform Extension.

The FloorBed Mattress Platform Extension is designed to facilitate the safe extension of the FloorBed mattress platform.

Before using this accessory, you must become acquainted in detail with this manual. All actions and handling of the FloorBed Mattress Platform Extension must be performed in accordance with the instructions in this manual.

Any actions that are inconsistent with the manual are performed at your own risk and Accora shall not be liable for any injury or damage. Please ensure that the manual is available to operators throughout the use of the FloorBed Mattress Platform Extension.

FloorBed Mattress Platform Extension should be regularly checked to ensure it is fitted correctly and functioning as intended for the user.

GENERAL WARNINGS

1. Keep this Instruction Manual available for future reference.
2. These instructions must be observed to ensure the safe and effective use of this FloorBed Mattress Platform Extension and the safety of users, carers and those around.
3. The FloorBed Mattress Platform Extension must be fitted, positioned and used in accordance with these instructions.
4. The safety features for using the FloorBed Mattress Platform Extension and instructions for use must be strictly observed.
5. The FloorBed Mattress Platform Extension must not be exposed to smoke, naked flame, extreme temperature, flammable gases or other hazardous substances or situations.
6. Accora shall not be held liable for any damage, injuries or accidents arising from unauthorised modifications, non-genuine spare parts, negligence or use that is at variance with this manual.
7. When routing cables for other electronic equipment used with the bed (e.g. an air mattress pump), ensure cables cannot be squeezed, crushed or damaged by any moving parts of the bed or by the FloorBed Mattress Platform Extension.
8. Never stand on the FloorBed Mattress Platform Extension.
9. Never attach anything to the FloorBed Mattress Platform Extension.
10. Do not move the bed by pulling or pushing on the FloorBed Mattress Platform Extension
11. Do not modify this FloorBed Mattress Platform Extension without the authorisation of Accora.
12. Patients, or users, should be risk assessed to ensure they can understand this manual and use the FloorBed Mattress Platform Extension safely without risk to themselves or others.
13. Accora shall not be held liable for any damage, injuries or accidents arising from negligence or use that is at variance with this manual.

1. Safety Instructions

1. Before using the FloorBed Mattress Platform Extension, you must read this manual and use the device in accordance with it.
2. The FloorBed Mattress Platform Extension may not be used if faults have been detected on it that may injure the patient, staff or a third person, or damage the FloorBed Mattress Platform Extension or the surroundings.
3. Before using the FloorBed Mattress Platform Extension, the operator should understand its functionality.
4. When replacing missing parts, only original materials and components must be used.

2. Intended use

The FloorBed Mattress Platform Extension accessory is intended for use with the FloorBed 1, FloorBed 1 Plus and FloorBed 2 models. The accessory is intended to be fitted when the bed frame has been extended to enable the gaps to be filled and the mattress to be supported.

It is essential to consult Accora in advance if you wish to use the FloorBed Mattress Platform Extension for any purpose outside the use detailed in this manual.

3. Technical specification

Environmental information:

Condition	Temperature Range	Relative Humidity	Atmospheric pressure
Operating	+10°C to +40°C +50°F to +104°F	30% to 75% (Non-condensing)	700 hPa to 1060 hPa
Transport/storage	-20°C to +50°C -4°F to +122°F		

If the FloorBed Mattress Platform Extension is stored in conditions outside the normal operating range, it should be allowed time to stabilise, in normal operating conditions, before use.

Description	Value		
	Extension	Fits bed	Weight
LRPEX-0-FL1-100	200mm 8in	NSB-0-FL1-200 NSB-0-FL2-200	1.8kg 4lbs
LRPEX-0-FL1-200	100mm 4in	NSB-0-FL1-200 NSB-0-FL1-200US NSB-0-FL2-200	1.3kg 2.9lbs
LRPEX-0-FL5-100	200mm 8in	NSB-0-FL5-100 NSB-0-FL5-200	3.8kg 8.4lbs
LRPEX-0-FL5-200	100mm 4in	NSB-0-FL5-200 NSB-0-FL5-200US	3.5kg 7.7lbs

4. Positioning

WARNING

The FloorBed Mattress Platform Extension MUST NOT be fitted while the bed is in use, i.e. has a person on the bed.

Only compatible mattress platform extensions, as supplied by Accora, may be fitted to the FloorBed.

The FloorBed Mattress Platform Extension must only be used when the FloorBed has been extended.

The FloorBed Mattress Platform Extension must be positioned at the foot end of the bed.

Ensure the FloorBed Mattress Platform Extension you have is the correct type to fit your FloorBed by identifying the model number of your FloorBed (shown on the Manufacturer's name plate on the inside of the frame at the head end) and using the table below.

Bed model number	To extend bed	FloorBed Mattress Platform Extension model number	Illustration number
NSB-0-FL1-200	100mm / 4in	LRPEX-0-FL1-200	1
	200mm / 8in	LRPEX-0-FL1-100	2
NSB-0-FL1-200US	100mm / 4in	LRPEX-0-FL1-200	1
NSB-0-FL2-200	100mm / 4in	LRPEX-0-FL1-200	1
	200mm / 8in	LRPEX-0-FL1-100	2
NSB-0-FL5-100	200mm / 8in	LRPEX-0-FL5-100	4
NSB-0-FL5-200	100mm / 4in	LRPEX-0-FL5-200	3
	200mm / 8in	LRPEX-0-FL5-100	4
NSB-0-FL5-200US	100mm / 4in	LRPEX-0-FL5-200	3

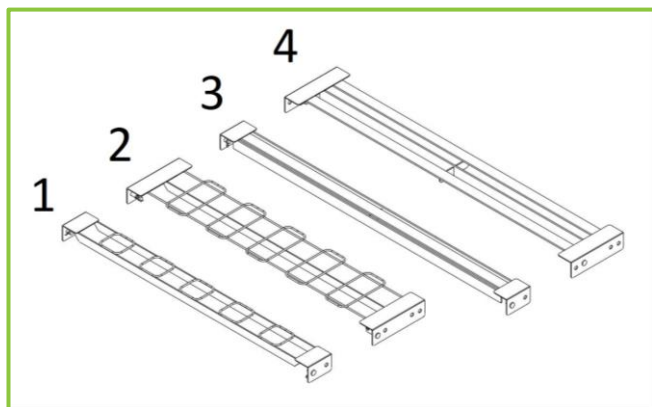

5. Fitting to FloorBed 1 (NSB-0-FL1-200) and FloorBed 2 (NSB-0-FL2-200)

WARNING

Fitting MUST be carried out by suitably trained and qualified personnel.

All functions MUST be tested and approved after fitting by suitably trained and qualified personnel.

Fitting MUST take place in a clear, uncluttered area and children and pets should be kept away.

The FloorBed Mattress Platform Extension MUST NOT be fitted while the bed is in use, i.e. has a person on the bed.

When routing cables and pipes for an air mattress pump, ensure cables cannot be squeezed, crushed or damaged by any moving parts of the bed or by the FloorBed Mattress Platform Extension.

1. Check the delivery is complete and undamaged. Do not use if any damage has occurred.
2. Ensure the FloorBed Mattress Platform Extension you have is the correct type to fit your FloorBed – see Section 4.
3. Remove accessories, bedding, mattress etc. from the bed and store in a safe place.
4. Check underneath and around the bed to make sure there are no obstructions or entrapment risks. Lower the bed to the Floor-level position, remove the power supply from the power source and store in a safe place.
5. Remove the mattress platform extension bar locking pins and R-clips, one either side of the bed:

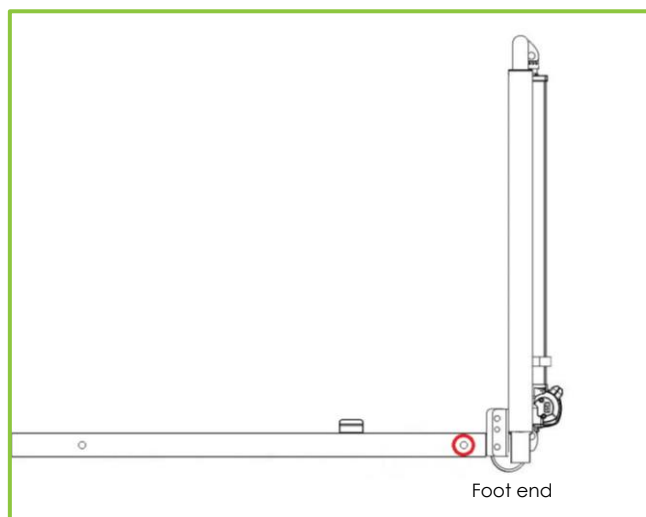

- Release the foot end castor brakes (refer to FloorBed User Manual) and carefully slide the mattress platform extension bars out of the mattress platform by gently pulling the foot board away from the platform:

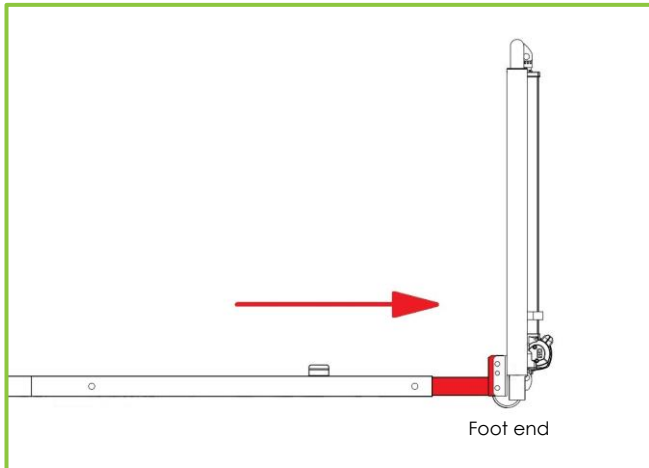

- Insert the locking pin, one either side of the bed, and secure with the R-clip using the correct hole position depending on the mattress platform extension length:

Bed model number	Mattress platform extension length	Mattress platform extension model number	Fitting hole for locking pin
NSB-0-FL1-200 NSB-0-FL2-200	Standard configuration	No extension fitted	1
	+100mm / 4in	LRPEX-0-FL1-200	2
	+200mm / 8in	LRPEX-0-FL1-100	3

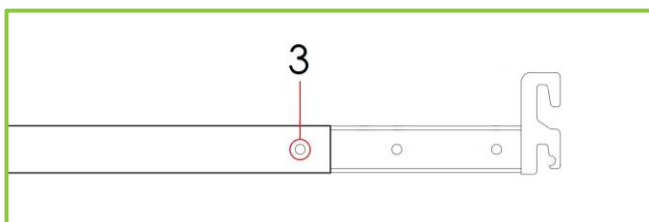
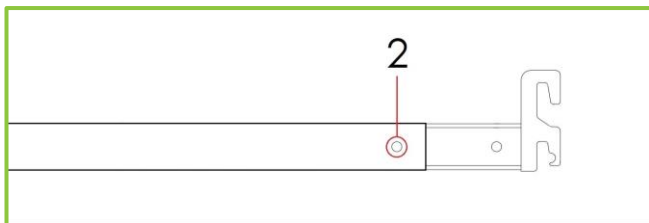
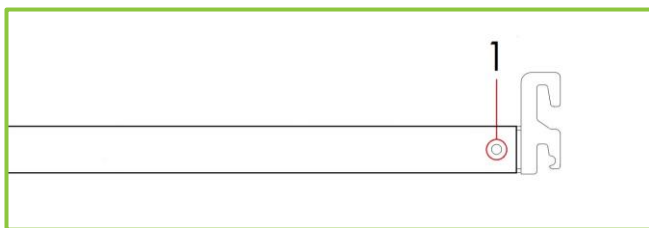

- Fit the FloorBed Mattress Platform Extension:

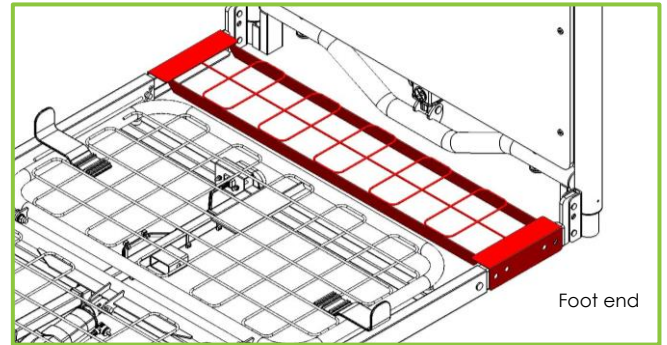

- Secure the FloorBed Mattress Platform Extension in place with the locking pins and R-clips using the holes that align in the FloorBed Mattress Platform Extension and the extension bar, one each side of the bed.
- Lock the castors (refer to FloorBed User Manual)
- Plug the power supply into a mains socket and switch the plug on.
- Test all functions of the bed (refer to Section 10 in the FloorBed User Manual)
- Refit mattress and accessories in accordance with the relevant User Manuals.

6. Fitting to FloorBed 1 USA (NSB-0-FL1-200US)

WARNING

Fitting **MUST** be carried out by suitably trained and qualified personnel.

All functions **MUST** be tested and approved after fitting by suitably trained and qualified personnel.

Fitting **MUST** take place in a clear, uncluttered area and children and pets should be kept away.

The FloorBed Mattress Platform Extension **MUST** not be fitted while the bed is in use, i.e. has a person on the bed.

When routing cables and pipes for an air mattress pump, ensure cables cannot be squeezed, crushed or damaged by any moving parts of the bed or by the FloorBed Mattress Platform Extension.

1. Check the delivery is complete and undamaged. Do not use if any damage has occurred.
2. Ensure the FloorBed Mattress Platform Extension you have is the correct type to fit your FloorBed – see Section 4.
3. Remove accessories, bedding, mattress etc. from the bed and store in a safe place.
4. Remove two foot end mattress from the lower legrest frame and store in a safe place.
5. Check underneath and around the bed to make sure there are no obstructions or entrapment risks. Lower the bed to the Floor-level position, remove the power supply from the power source and store in a safe place.
6. Remove the mattress platform extension bar locking pins and R-clips, one either side of the bed:

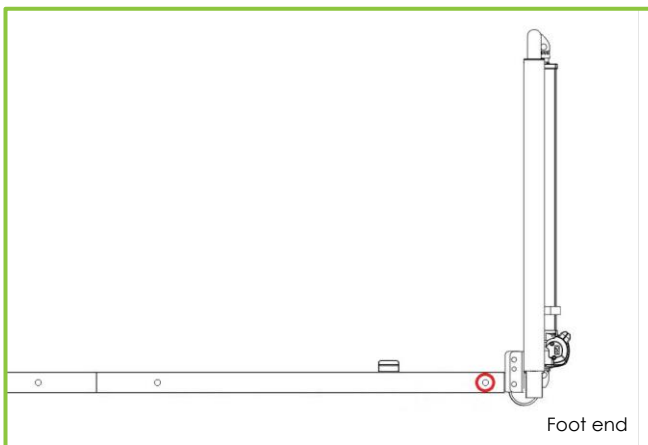

7. Release the foot end castor brakes (refer to FloorBed User Manual) and carefully slide the mattress platform extension bars out of the mattress platform by gently pulling the foot board away from the platform:

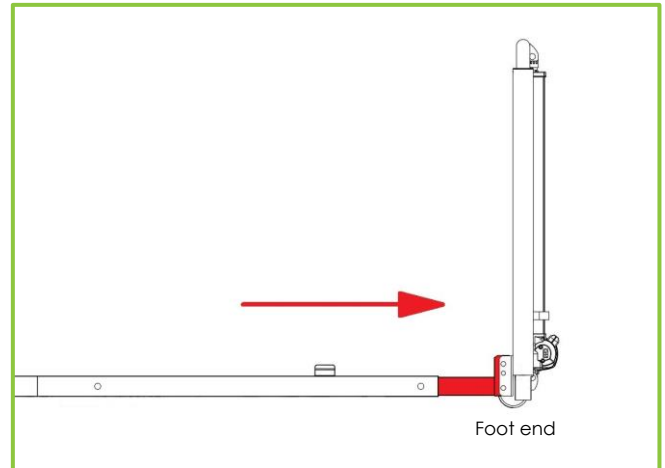

8. Insert the locking pin, one either side of the bed, and secure with the R-clip using the correct hole position depending on the mattress platform extension length:

Bed model number	Mattress platform extension length	Mattress platform extension model number	Fitting hole for locking pin
NSB-0-FL1-200US	Standard configuration	No extension fitted	1
	+100mm / 4in	LRPEX-0-FL1-200	2
	+200mm / 8in	Not available	N/A

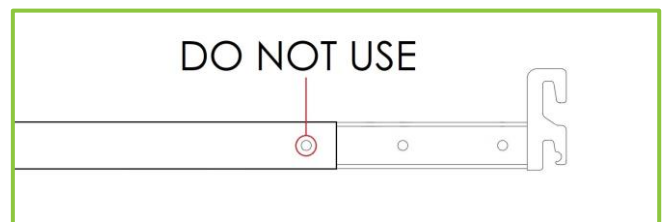
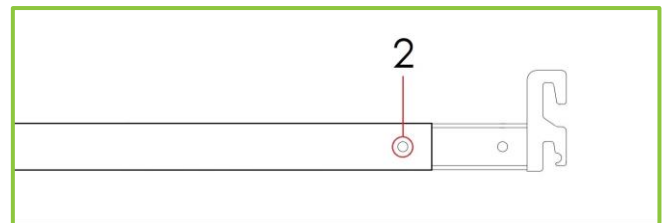
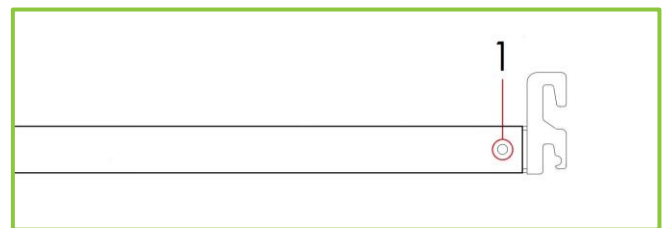

9. Fit the FloorBed Mattress Platform Extension:

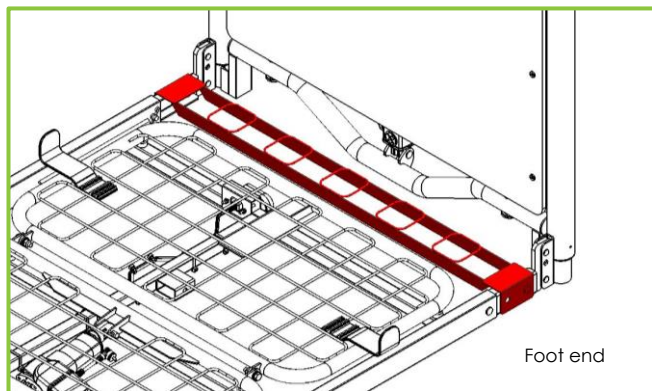

10. Secure the FloorBed Mattress Platform Extension in place with the locking pins and R-clips using the holes that align in the FloorBed Mattress Platform Extension and the extension bar, one each side of the bed.

11. Lock the castors (refer to FloorBed User Manual)

12. Fit the foot end mattress guides to the lower legrest frame using fitting slot 2 as shown below:

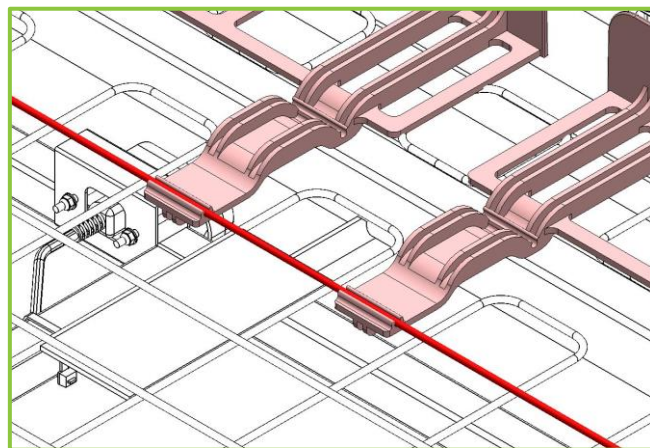
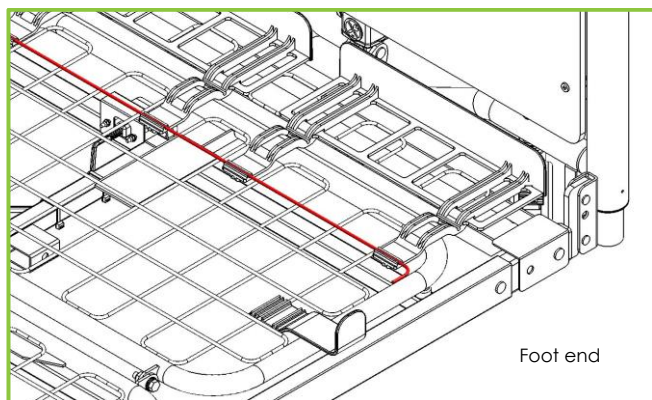
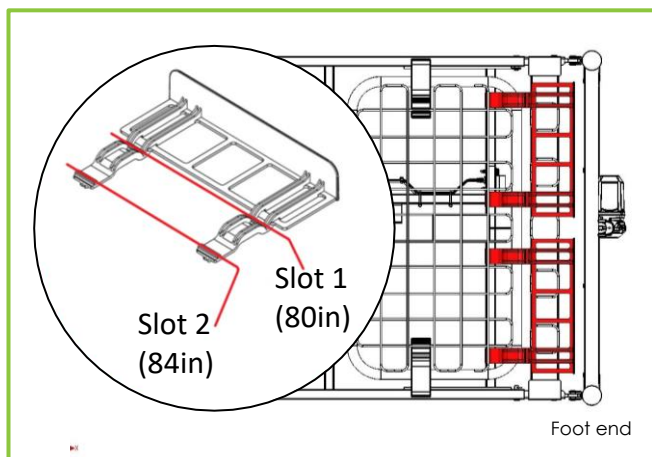

13. Plug the power supply into a mains socket and switch the plug on.

14. Test all functions of the bed (refer to Section 10 in the FloorBed User Manual)

15. Refit mattress and accessories in accordance with the relevant User Manuals.

7. Fitting to FloorBed 1 Plus (NSB-0-FL5-100)

WARNING

Fitting **MUST** be carried out by suitably trained and qualified personnel.

All functions **MUST** be tested and approved after fitting by suitably trained and qualified personnel.

Fitting **MUST** take place in a clear, uncluttered area and children and pets should be kept away.

The FloorBed Mattress Platform Extension **MUST** not be fitted while the bed is in use, i.e. has a person on the bed.

When routing cables and pipes for an air mattress pump, ensure cables cannot be squeezed, crushed or damaged by any moving parts of the bed or by the FloorBed Mattress Platform Extension.

1. Check the delivery is complete and undamaged. Do not use if any damage has occurred.
2. Ensure the FloorBed Mattress Platform Extension you have is the correct type to fit your FloorBed – see Section 4.
3. Remove accessories, bedding, mattress etc. from the bed and store in a safe place.
4. Loosen the mattress platform extension bar locking screws in 4 places using a 5mm hex Allen key. Do not remove the locking pins and R-clips at this stage.

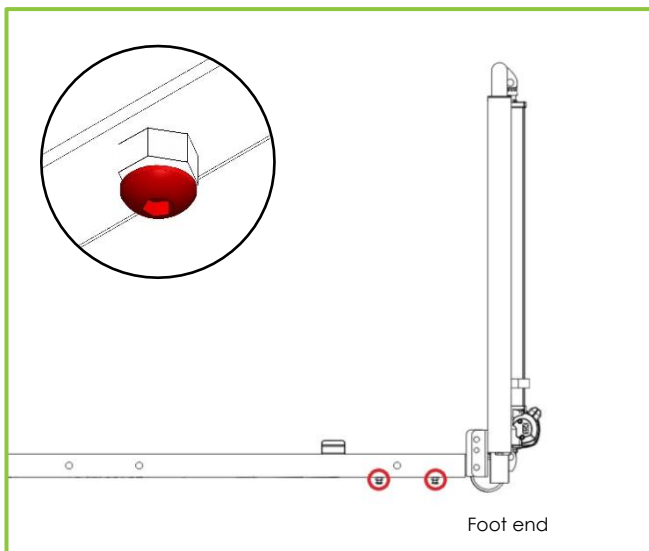

5. Check underneath and around the bed to make sure there are no obstructions or entrapment risks. Lower the bed to the Floor-level position, remove the power supply from the power source and store in a safe place.
6. Remove the mattress platform extension bar locking pins and R-clips, one either side of the bed:

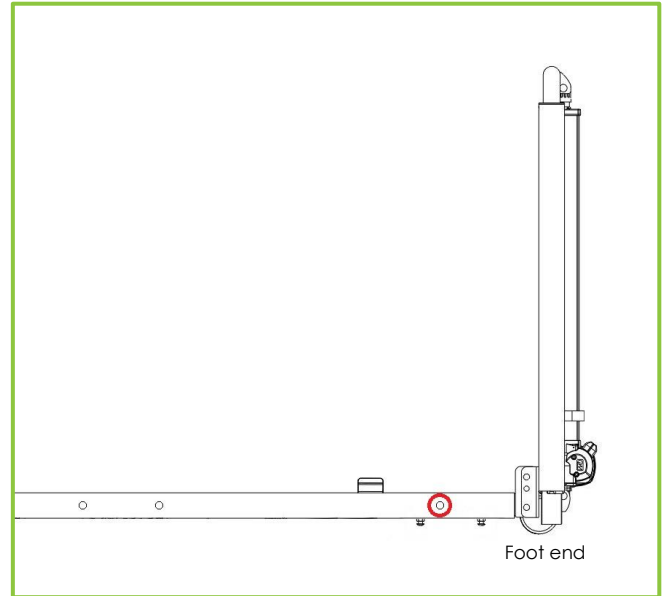

7. Release the foot end castor brakes (refer to FloorBed User Manual) and carefully slide the mattress platform extension bars out of the mattress platform by gently pulling the foot board away from the platform:

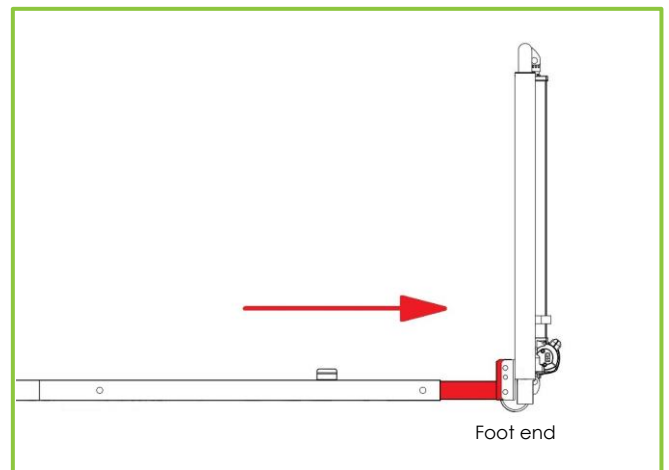

8. Insert the locking pin, one either side of the bed, and secure with the R-clip using the correct hole position depending on the mattress platform extension length:

Bed model number	Mattress platform extension length	Mattress platform extension model number	Fitting hole for locking pin
NSB-0-FL5-100	Standard configuration	No extension fitted	1
	+200mm / 8in	LRPEX-0-FL5-100	2

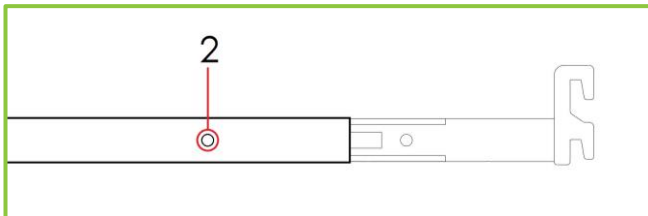
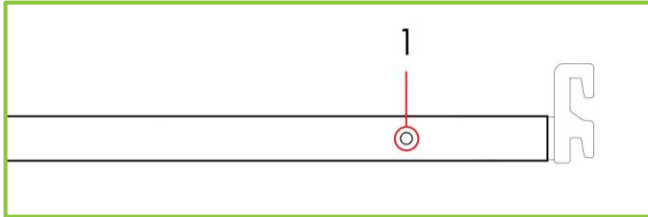

9. Fit the FloorBed Mattress Platform Extension:

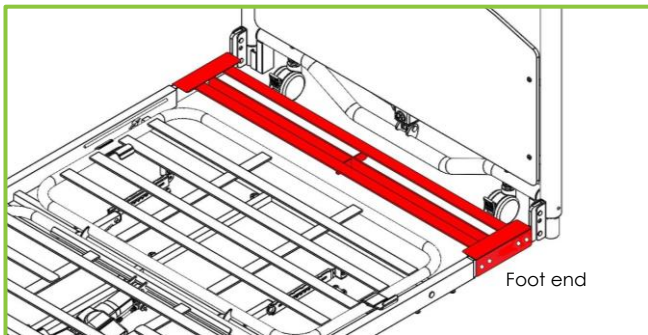

10. Secure the FloorBed Mattress Platform Extension in place with the locking pins and R-clips using the holes that align in the FloorBed Mattress Platform Extension and the extension bar, one each side of the bed.
11. Lock the castors (refer to FloorBed User Manual)
12. Plug the power supply into a mains socket and switch the plug on.
13. Raise the bed and tighten the mattress platform extension bar locking screws in 4 places using a 5mm hex Allen key:

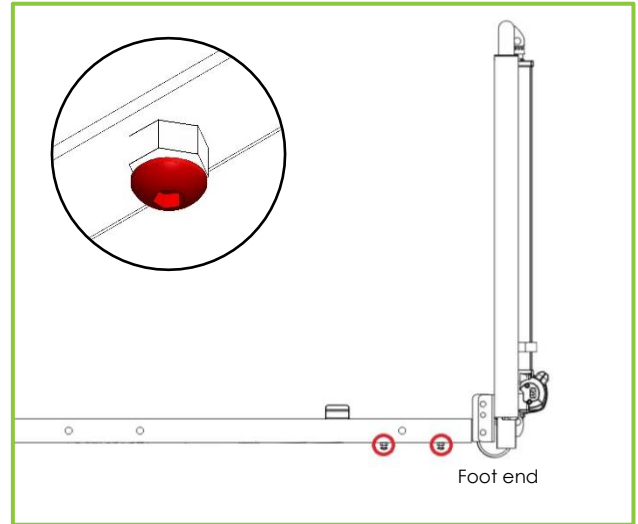

14. Test all functions of the bed (refer to FloorBed User Manual)
15. Refit mattress and accessories in accordance with the relevant User Manuals.

8. Fitting to FloorBed 1 Plus (NSB-0-FL5-200)

WARNING

Fitting **MUST** be carried out by suitably trained and qualified personnel.

All functions **MUST** be tested and approved after fitting by suitably trained and qualified personnel.

Fitting **MUST** take place in a clear, uncluttered area and children and pets should be kept away.

The FloorBed Mattress Platform Extension **MUST** not be fitted while the bed is in use, i.e. has a person on the bed.

When routing cables and pipes for an air mattress pump, ensure cables cannot be squeezed, crushed or damaged by any moving parts of the bed or by the FloorBed Mattress Platform Extension.

1. Check the delivery is complete and undamaged. Do not use if any damage has occurred.
2. Ensure the FloorBed Mattress Platform Extension you have is the correct type to fit your FloorBed – see Section 4.
3. Remove accessories, bedding, mattress etc. from the bed and store in a safe place.
4. Loosen the mattress platform extension bar locking screws in 4 places using a 5mm hex Allen key. Do not remove the locking pins and R-clips at this stage.

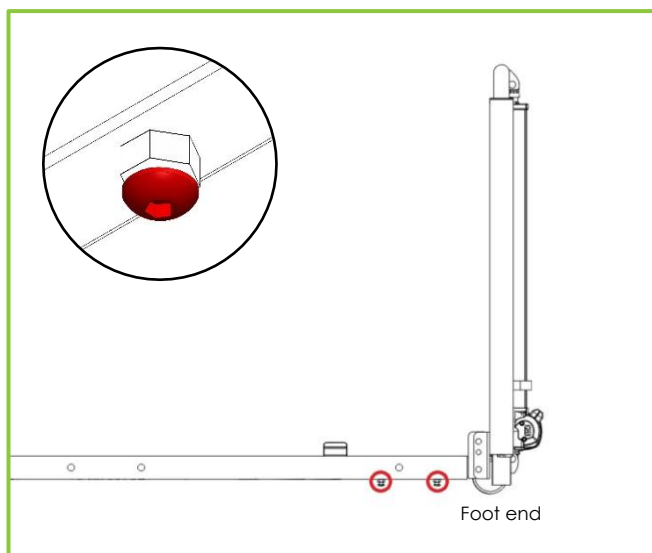

5. Check underneath and around the bed to make sure there are no obstructions or entrapment risks. Lower the bed to the Floor-level position, remove the power supply from the power source and store in a safe place.
6. Remove the mattress platform extension bar locking pins and R-clips, one either side of the bed:

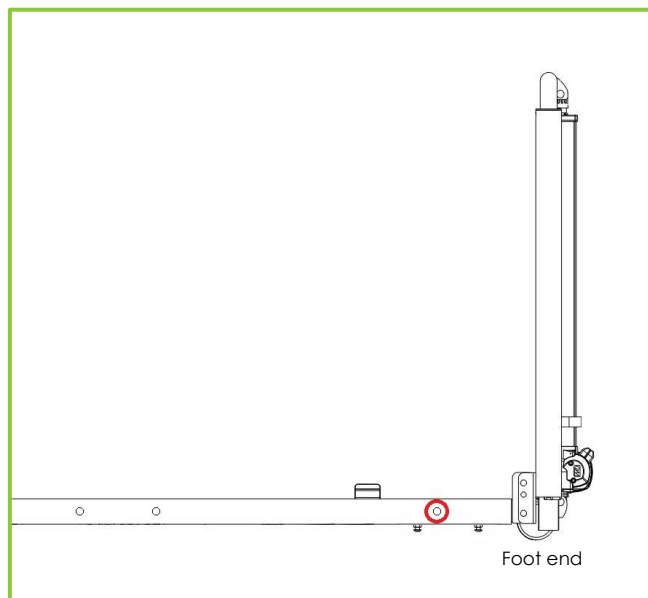

7. Release the foot end castor brakes (refer to FloorBed User Manual) and carefully slide the mattress platform extension bars out of the mattress platform by gently pulling the foot board away from the platform:

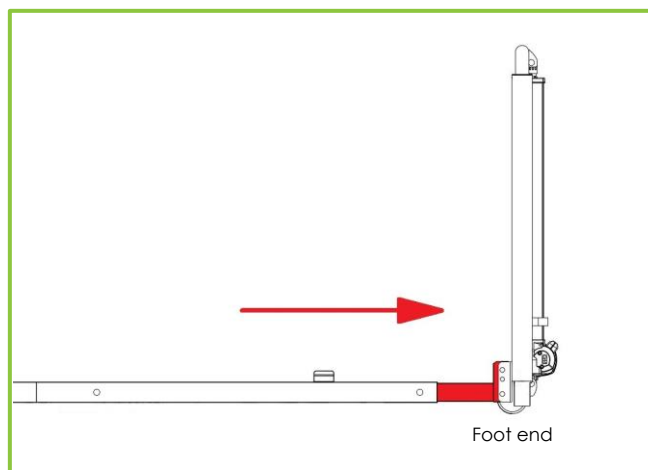

8. Insert the locking pin, one either side of the bed, and secure with the R-clip using the correct hole position depending on the mattress platform extension length:

Bed model number	Mattress platform extension length	Mattress platform extension model number	Fitting hole for locking pin
NSB-0-FL5-100	Standard configuration	No extension fitted	1
	+100mm / 4in	LRPEX-0-FL5-200	2
	+200mm / 8in	LRPEX-0-FL5-100	3

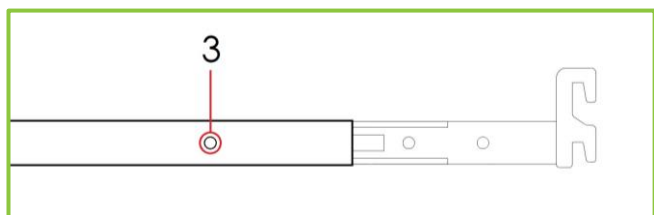
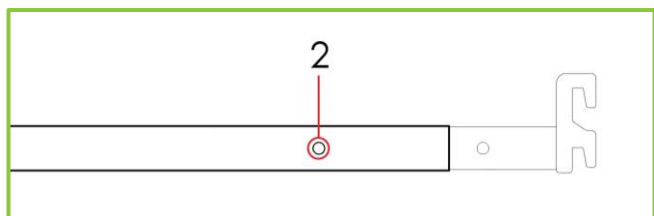
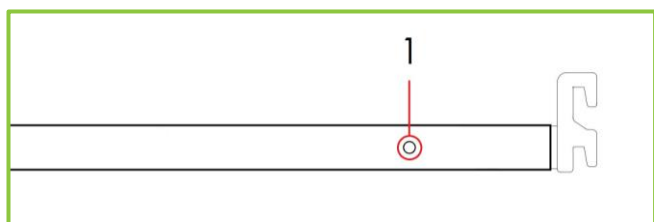

9. Fit the FloorBed Mattress Platform Extension:

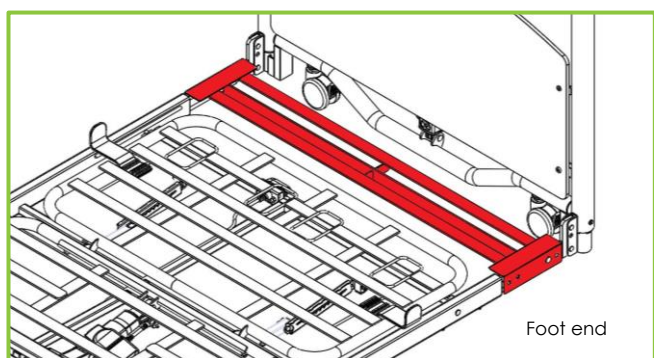

10. Secure the FloorBed Mattress Platform Extension in place with the locking pins and R-clips using the holes that align in the FloorBed Mattress Platform Extension and the extension bar, one each side of the bed.

11. Lock the castors (refer to FloorBed User Manual)

12. Plug the power supply into a mains socket and switch the plug on.

13. Raise the bed and tighten the mattress platform extension bar locking screws in 4 places using a 5mm hex Allen key:

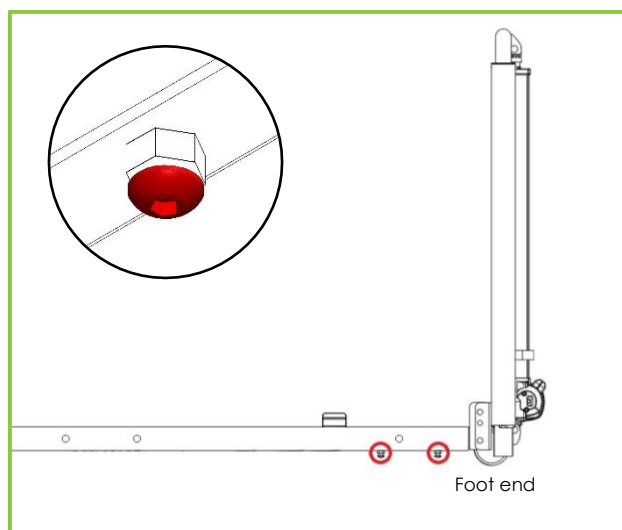

14. Test all functions of the bed (refer to FloorBed User Manual)

15. Refit mattress and accessories in accordance with the relevant User Manuals.

9. Fitting to FloorBed 1-Plus USA (NSB-0-FL5-200US)

WARNING

Fitting **MUST** be carried out by suitably trained and qualified personnel.

All functions **MUST** be tested and approved after fitting by suitably trained and qualified personnel.

Fitting **MUST** take place in a clear, uncluttered area and children and pets should be kept away.

The FloorBed Mattress Platform Extension **MUST** not be fitted while the bed is in use, i.e. has a person on the bed.

When routing cables and pipes for an air mattress pump, ensure cables cannot be squeezed, crushed or damaged by any moving parts of the bed or by the FloorBed Mattress Platform Extension.

1. Check the delivery is complete and undamaged. Do not use if any damage has occurred.
2. Ensure the FloorBed Mattress Platform Extension you have is the correct type to fit your FloorBed – see Section 4.
3. Remove accessories, bedding, mattress etc. from the bed and store in a safe place.
4. Remove two foot end mattress from the lower legrest frame and store in a safe place.
5. Loosen the mattress platform extension bar locking screws in 4 places using a 5mm hex Allen key. Do not remove the locking pins and R-clips at this stage.

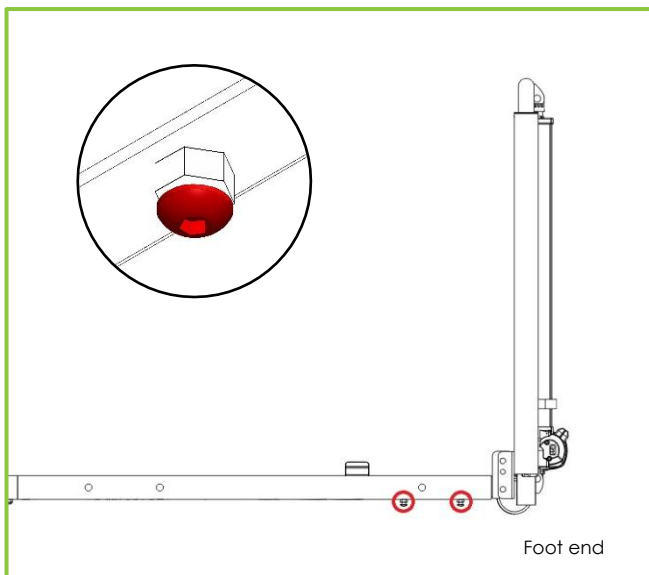

6. Check underneath and around the bed to make sure there are no obstructions or entrapment risks. Lower the bed to the Floor-level position, remove the power supply from the power source and store in a safe place.
7. Remove the mattress platform extension bar locking pins and R-clips, one either side of the bed:

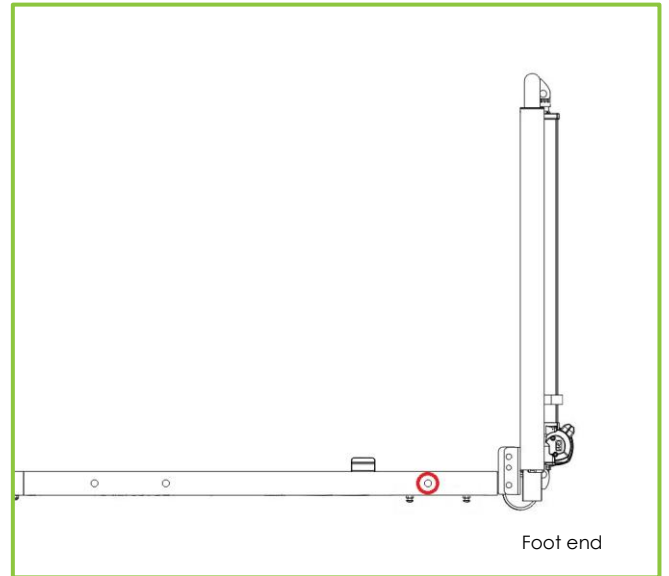

8. Release the foot end castor brakes (refer to FloorBed User Manual) and carefully slide the mattress platform extension bars out of the mattress platform by gently pulling the foot board away from the platform:

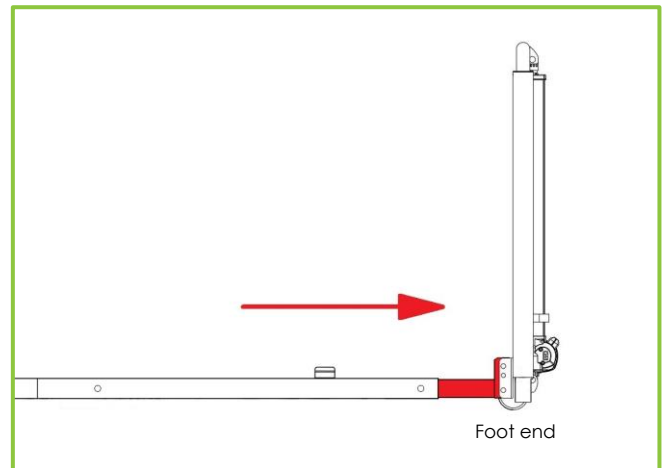

9. Insert the locking pin, one either side of the bed, and secure with the R-clip using the correct hole position depending on the mattress platform extension length:

Bed model number	Mattress platform extension length	Mattress platform extension model number	Fitting hole for locking pin
NSB-0-FL5-200US	Standard configuration	No extension fitted	1
	+100mm / 4in	LRPEX-0-FL5-200	2
	+200mm / 8in	Not available	N/A

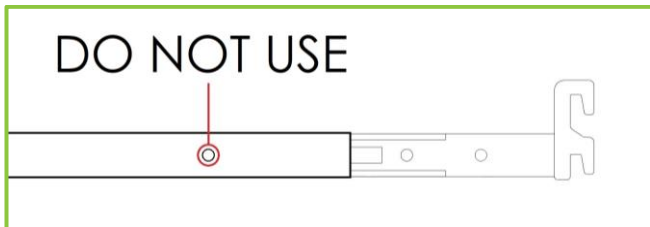
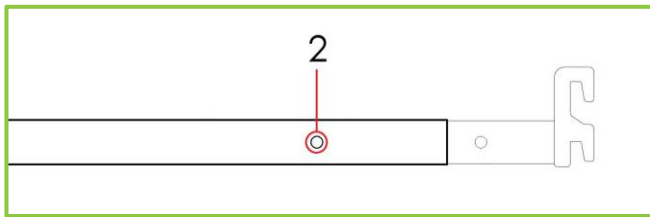
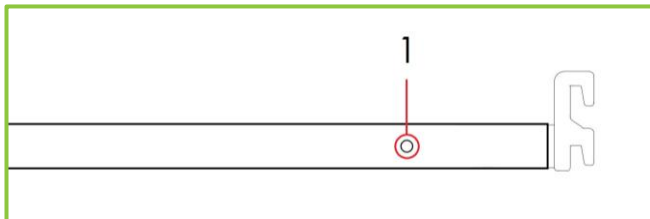

10. Fit the FloorBed Mattress Platform Extension:

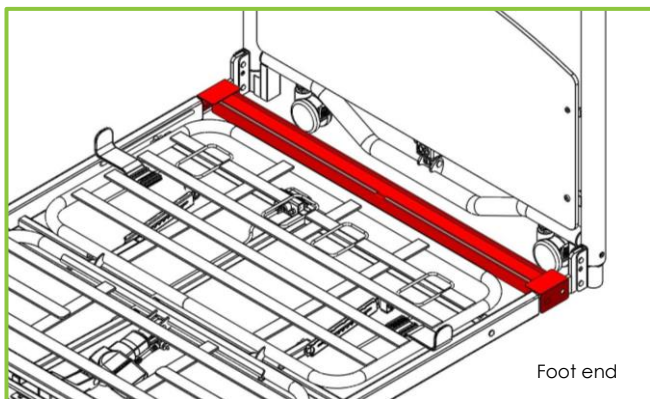

11. Secure the FloorBed Mattress Platform Extension in place with the locking pins and R-clips using the holes that align in the FloorBed Mattress Platform Extension and the extension bar, one each side of the bed.

12. Lock the castors (refer to FloorBed User Manual)

13. Fit the foot end mattress guides to the lower legrest frame using fitting slot 2 as shown below:

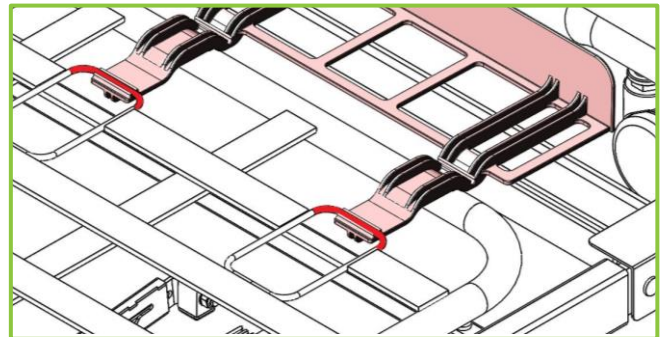
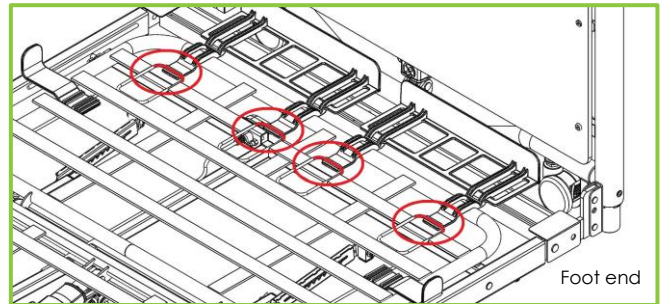
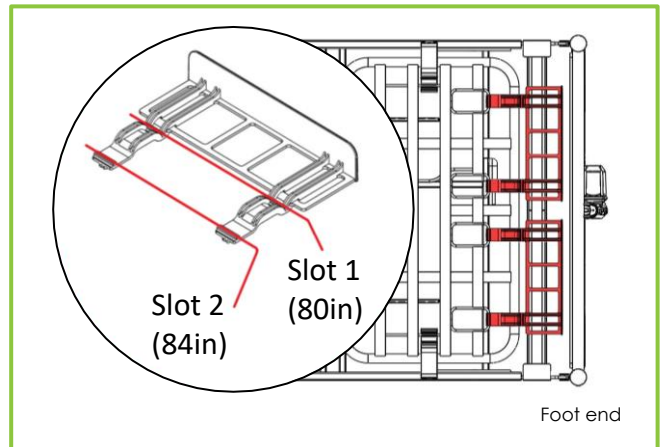

14. Plug the power supply into a mains socket and switch the plug on.

15. Raise the bed and tighten the mattress platform extension bar locking screws in 4 places using a 5mm hex Allen key (See step 5).

16. Test all functions of the bed (refer to Section 10 in the FloorBed User Manual)

17. Refit mattress and accessories in accordance with the relevant User Manuals.

10. Functionality check

WARNING

Functionality check MUST be carried out by suitably trained and qualified personnel.

All FloorBed Mattress Platform Extension functions MUST be tested and approved by suitably trained and qualified personnel.

Functionality check must not be carried out with the bed occupied.

When routing cables and pipes for an air mattress pump, ensure cables cannot be squeezed, crushed or damaged by any moving parts of the bed or by FloorBed Mattress Platform Extension.

1. Check the FloorBed Mattress Platform Extension is the correct type for the bed. See Section 4.
2. Check the FloorBed Mattress Platform Extension is fitted correctly to the bed. See Sections 5 to 9 as appropriate.
3. Check that no cables or pipes are at risk of being squeezed, crushed or damaged by any moving parts of the bed or by the FloorBed Mattress Platform Extension.

11. Cleaning and Disinfection

WARNING

Cleaning and disinfection MUST be carried out by suitably trained and qualified personnel.

All functions MUST be tested and approved by suitably trained and qualified personnel.

The FloorBed Mattress Platform Extension MUST be cleaned and disinfected before re-using the bed for a different patient.

To disinfect the FloorBed Mattress Pump Mount, only use detergents designed for use in healthcare. Do not use abrasives, scourers or other materials that could damage the coating. Do not use corrosives, caustics or strong acids.

Do not use detergents that could alter the structure or behaviour of the plastics (petrol etc.).

12. Storage

For problem-free storage we recommend:

1. FloorBed Mattress Platform Extension should be stored in a temperature between -20°C to +50°C, -4°F to +122°F
2. FloorBed Mattress Platform Extension should be stored in a relative humidity (non-condensing) between 30% and 75%

13. Guarantee

The warranty period for the FloorBed Mattress Platform Extension is 2 years.

14. Disposal

In the event of the disposal of the FloorBed mattress Pump Mount, end-of-life parts must be disposed of in accordance with current environmental regulations.

15. Contact details

	UK and Rest of World	USA
Address	Accora Ltd. Charter House Barrington Road Orwell Cambridge SG8 5QP UK	Accora Inc. 6021 University Blvd Suite 530 Ellicott City MD 21043 USA
Telephone	+44 (0)1223 206100	+1 301-560-2400
Email	info@accora.uk.com	information@accora.us.com
Website	www.floorbed.com	www.floorbed.com

Accora



Accora
Charter House
Barrington Road
Orwell
Cambridge
SG8 5QP

T: +44 (0)1223 206100
F: +44 (0)1223 206120
info@accora.uk.com
www.accora.uk.com