



ComfortSystem – our experience is your guarantee

Instructions for users of Qvintett hospital beds

with motor systems CS2



ComfortSystem
– our experience is your guarantee



Read the instructions
before using the bed!

CE



List of Contents

- instructions

1. Introduction
2. Field of application
3. Important to bear in mind
4. Electronics/Motors
5. Assembly/dismantling
6. Assembly/dismantling model H (*option*)
7. Removing the electronics box
8. Instructions for use
9. Accessories
10. Technical Specifications
11. Environment, Transport and Storage
12. Maintenance and reconditioning
13. Troubleshooting schedule motor and electronics
14. Maintenance Schedule
15. Inspection Report
16. Delivery control



1. Introduction

Congratulations on your choice of QVINTETT hospital bed from Comfort System Scandinavia AB. To guarantee that our products are manufactured with a uniform and high quality, as well as with as little environmental impact as possible, Comfort System Scandinavia AB is certified according to ISO 9001 and ISO 14001.

Every bed is manufactured in Sweden according to strict quality standards and each bed is tested in the factory. Each bed is accompanied by a signed control report describing the various parts that have been tested.

ComfortSystem Scandinavia AB

Box 4034, Vistakullevägen 18
561 04 HUSKVARNA, Sweden
Tfn +46 (0)36 51590
Fax +46 (0)36 50001
info@comfortsystem.se
www.comfortsystem.se

The following applies to QVINTETT hospital beds:

- QVINTETT is CE-marked according to Directive 93/42/EEG
- QVINTETT has been subjected to a risk analysis according to EN14971
- QVINTETT is tested and certified according to IEC/FDIS 60601-2-52 by Hjälpmedelsinstitutet, an independent testing institute in Denmark
- QVINTETT electrical system is tested and certified according to EN60601-1 / 60601-1-2 by NEMKO in Norway



2. Field of application

QVINTETT Hospital Bed is to be used as a personal aid or care aid in a domestic or institutional environment, e.g. nursing homes, homes designed for the elderly or similar.

The product and the associated accessories are intended for individuals older than 12 years of age.

For information on the SWL (Safe Working Load) and the maximum user weight – see the nameplate on the bed lift.

The product is only to be used in normal indoor environments with temperatures in the range of +10 to +40 degrees.

The product may only be matched and used together with accessories approved by Comfort System Scandinavia AB.

The product may only be used for the intended field of application.

If the bed's functions change or cease to function, it must be checked immediately according to the instructions for maintenance/reconditioning as well as the troubleshooting schedule.





3. Important to bear in mind



The bed should not be used by people of restricted growth, whose body size is equivalent to that of a 12-year old or younger, without carrying out a documented risk assessment. In particular, the risk of the user coming through/getting stuck in the bed's openings in the rail system, ends, bed bottom as well as any mounted accessories, has to be evaluated.



To reduce the risk of injuries associated with falling out of bed or similar incidents, the bed must always be left in the lowest position when the user is left alone in bed. This applies even if the bed rails are used.



If the bed and bed rails/accessories are to be used by people who are confused, disturbed or suffer from spasms, a risk analysis has to be carried out to identify exceptional risks due to the user's condition/behaviour. Consider using the block function to switch off motors when carers are not in the vicinity.



The bed fulfils current requirements for electromagnetic interference. Despite this, interference may arise from/to other electrical devices. To reduce/eliminate interference – increase the distance to the products or switch them off.



Comfort System Scandinavia AB does not accept any liability for the product if it is altered, assembled or used in any other way than that set out in these instructions.



4. Electronics/Motors

4.1 Electrical data, motor system CS2*

Connection voltage:	220-240 V [~] /50 Hz
Max. current consumption:	4 A
Intermittence (periodic use of motors):	10% max 2 min rest 18 min
Enclosure class (Electronics/motors):	IP54/X6
Noise:	47 dB

Alternating current:



Direct current:



The patient is not isolated from earth and chassis:



* Motor system CS2, shortened CS2



4.2 Electronic components, motor system CS2

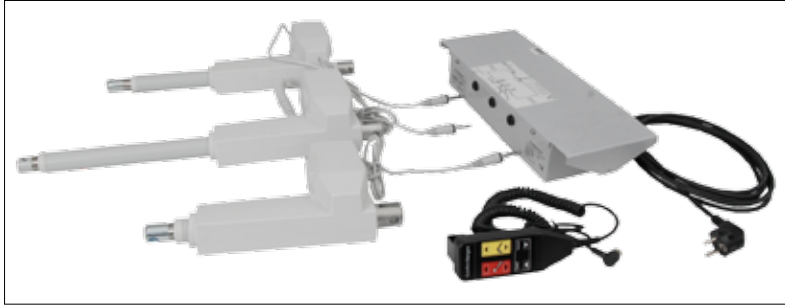

Complete bed has the following electrical components

1. Electronics box incl. transformer art. no. 9504
2. Hand control art. no. 8003
3. Lift motor art. no. 9501
4. Back motor art. no. 9505
5. Foot motor art. no. 9503

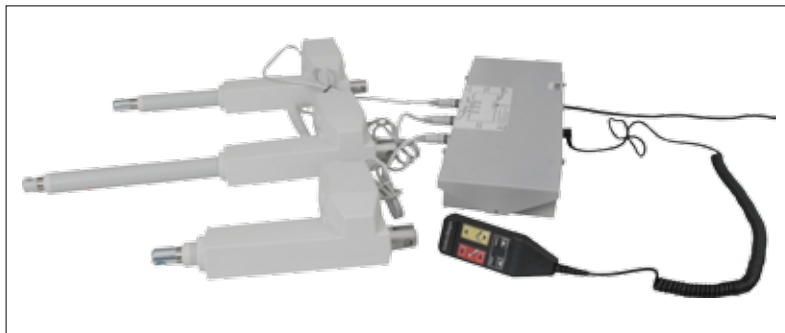



5. Assembly Instructions

Normally, QVINTETT is delivered assembled (excl. bed frame), in which case, skip over points 5.1 to 5.4!

5.1 Place the sprung base on the bed lift

For the correct working position – connect the bed lift to a wall socket and run the bed lift up to a suitable working height (see instructions for use). Place the sprung base on the bed lift as shown in the figure.

NOTE! The bed's foot end has to be placed over the bed lift's foot end (over the lift motor) – see point 5.2.



5.2 Correct placement

Correct placement means that the sprung base's quick release has to match the bed lift's fastener plates - two fasteners in the foot end and one fastener on the head end.

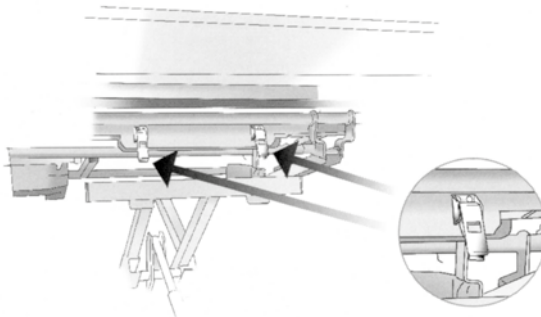



5.3 The sprung base's quick release

Hook the quick release's hook in the sprung base's fastener plate. Lift the quick release's top section so the hook 'falls down'. Press down the quick release's top section and ensure the catch locks in this position.

When dismantling: release the quick release's top section by pressing the lock mechanism down, lift up the top section and release the hook.

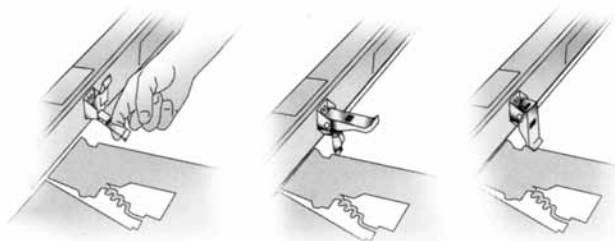

5.4 Connecting the motors

Connect the sprung base's back and foot motors to the bed lift's electronics box. See the marking on the electronics box's cover. To make it easier to connect the contacts – gently lift inside the electronics box.

NOTE! The motor cables have to run over the bed lift's transverse and longitudinal tube (see figure).

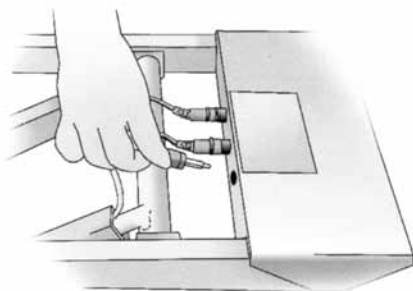



5.5 Adjustment of the length

The length of the sprung base can be regulated by adjusting the sprung base's foot end and the mattress stop. Before adjusting – take note how the marks in the foot end (small depressions) are placed in relation to the sprung base. Loosen the Allen keys and adjust to the desired length in steps of 5 centimetres. Place the foot end's marks so they correspond to the starting position and tighten the Allen keys. Adjust the mattress stop in the same way.

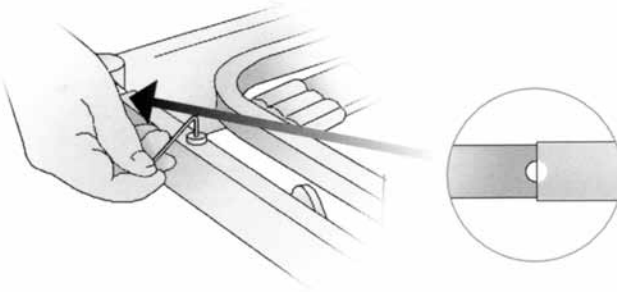

5.6 Assembly of the bed end/long sides

Mount the screw head on the stud bolt. Place the bolt in the bed end's pre-drilled hole. Place the bed end against the sprung base so that the bolt fits into the sprung base's end plates. Screw the nuts into place and tighten so the bed end is stable.

If fixed long sides are to be assembled, carry out corresponding assembly on the sprung base's longitudinal profile tube.

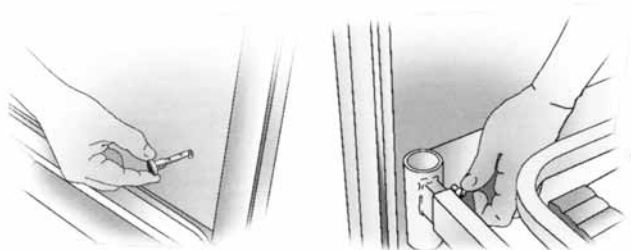



5.7 Handling the parts of the sprung base

On QVINTETT model A/H with CS2, the sprung base's thigh/foot section can be easily lifted out of the sprung base. Fold up the selected section so it stands at right angles to the sprung base. Lift straight up, so the part is released from the attachment points. The back section can be folded up manually for cleaning etc.

NOTE! Make use of this option when handling the bed in cramped spaces to reduce the weight of the parts being handled or when cleaning.

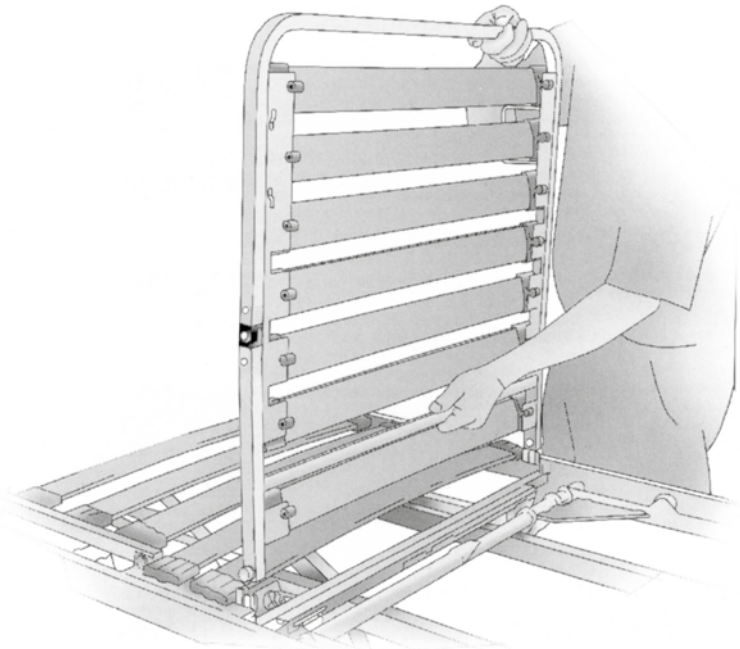



6. Assembly instructions sprung base model H with CS2 (option)

To make transport and assembly in cramped spaces easier, the sprung base can be divided into three sections (the description is based on a position where the sprung base is mounted on the bed lift).

NOTE! Raise the bed lift to a suitable working height before starting work.

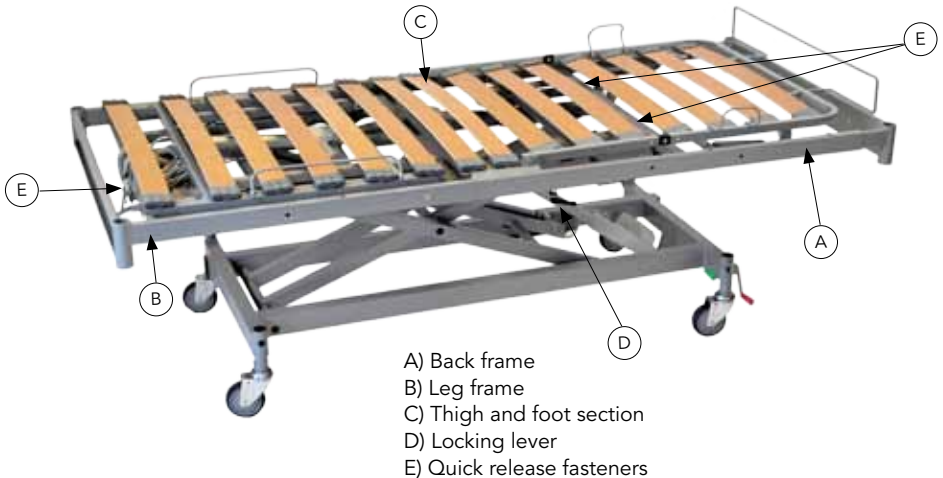

6.1 Remove thigh and foot section

Angle up the thigh and foot section (C) to 90 degrees. Lift the section straight up.





6.2 Release the sprung base

Pull out the motor contacts to the back and foot motors. Release the three quick release fasteners (E). Rotate the two locking levers (D) to loosen, so they hang free.



6.3 Loosen leg frame

Grip the leg frame (B) by the end plate. Lift, so the frame comes free, and pull it towards you. Lower, and place the frame on the floor.



6.4 Loosen the back frame

Grip the back frame (A) by the end plate. Lift, so the frame comes free, and pull it towards you. Lower, and place the frame on the floor.



6.5 To assemble

Do steps 1 to 4 above in the reverse order.



7. Removing the electronics box

The electronics box is installed in the bed lift under the sprung base's head end.

NOTE! During dismantling, the box must NOT be connected to the wall socket. During assembly – do the above in the reverse order.

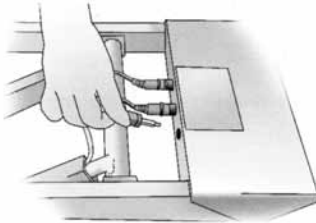

1. Detach the motor cables

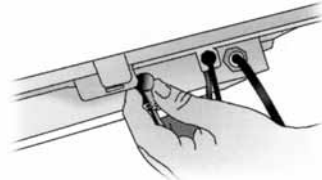

2. Unplug the cable contact from the hand control.

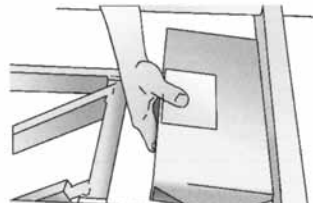
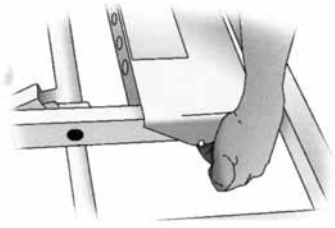

3. On the sides of the box there are small plastic studs to secure it during transport – take these off and lift out the electronics box.



8. Instructions for use

8.1. Power supply

Connect the bed's mains cable to a wall socket.

The bed's motors are driven by a low voltage system (24V). The system is powered via a transformer built into the electronics box.

⚠ Check that the mains cable is not pinched or stuck.

⚠ If the power is to be interrupted to the bed, unplug the mains cable from the wall socket.

8.2 Locking the wheels

The bed can be equipped with individually or centrally lockable wheels. In the case of individual locking – press down the small catch on the respective wheel. Release by pressing the catch towards the bed.

⚠ Always lock at least two wheels.

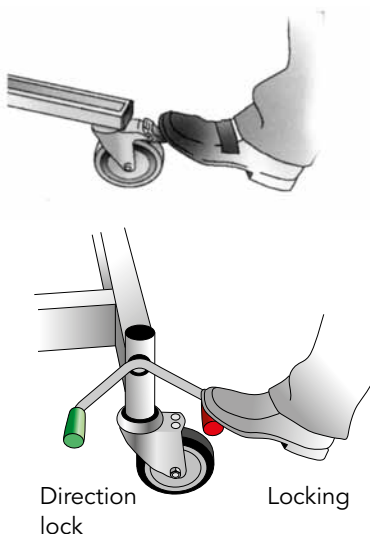

Central Locking

Press one of the pedals that are in the end of the bed.

- Press the red pedal = lock.
- Press the green pedal = directional lock (If the sitlocation will be used, raise the bed from the bottom ca 5 cm.).
- Pedal in a horizontal position = neutral.



8.3 Controlling the bed lift

The bed can be raised/lowered using an electrically powered motor (low voltage).

The bed lift is controlled from the control unit. Buttons for UP or DOWN can be seen in the sketch below.

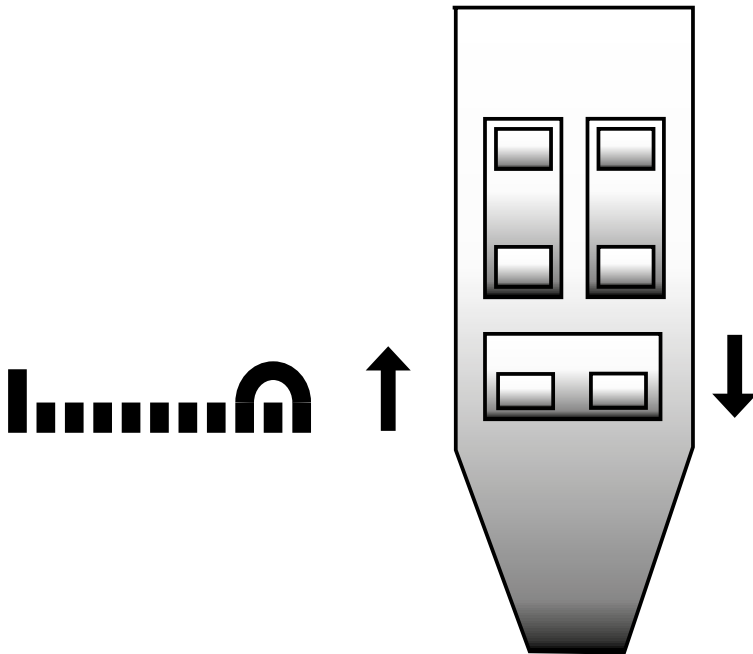

 For the loading – see the marking on the bed lift.

SWL for type C = 235 kg (user weight 200 kg)



SWL for type B = 200 kg (user weight 165 kg)



 Check that there is free space above the bed when the bed is raised.

 Check that the bed can move freely when it is lowered.

 Check that the mains cable and cable to the control unit are not pinched or stuck while raising or lowering.



8.4 Controlling the backrest

The bed backrest can be raised/lowered using an electrically powered motor (low voltage).

The bed backrest is controlled from the control unit. Buttons for UP or DOWN can be seen in the sketch below.

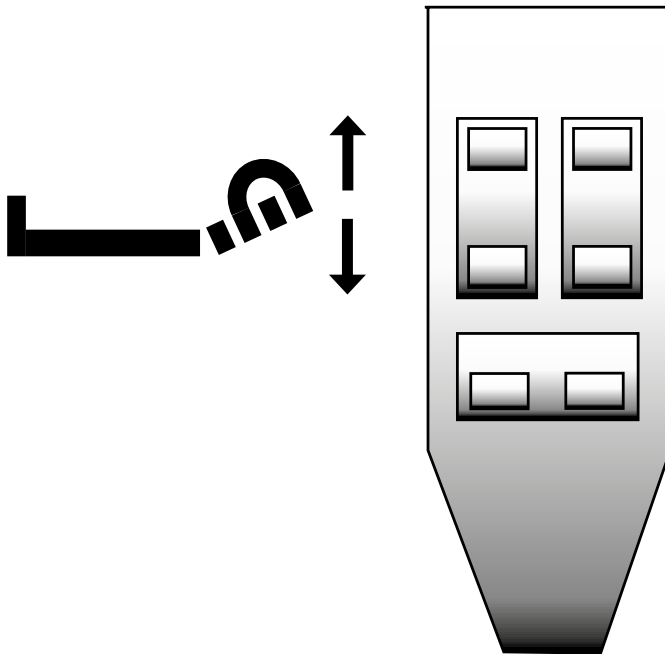

- ⚠ Check that there is free space for the bed backrest so it can lift up/ forwards.
- ⚠ Check that there is nothing behind/under the bed backrest when it is lowered down/backwards.
- ⚠ Check that no part of the body is at risk of catching in the bed rails, grab rail etc.



8.5 Controlling the thigh and foot section – Comfort QVINTETT

On the Comfort QVINTETT, the thigh and foot section can be raised/ lowered using an electrically powered motor (low voltage).

The thigh and foot section is controlled from the control unit. Buttons for UP or DOWN can be seen in the sketch below.

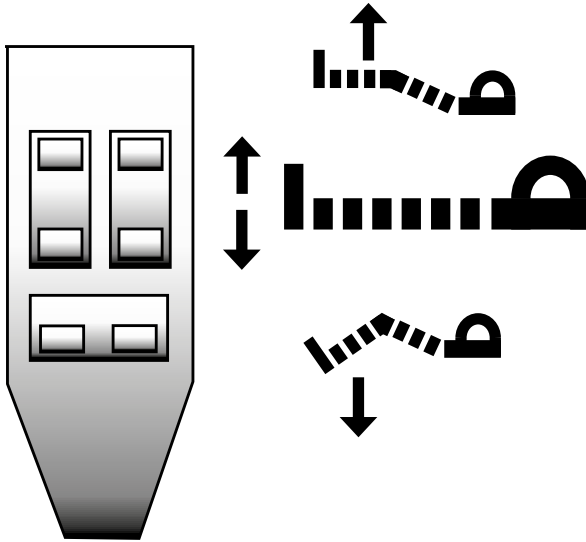

⚠ Check that there is free space for the thigh and foot section, so it can be raised upwards/backwards.

⚠ Check that there is nothing under the thigh and foot section when it is lowered down/forwards and that no parts of the body risk catching in the bed rails, grab rails etc.

When using:

The thigh and foot section is controlled by the same motor.

If the control unit's UP button is activated, the thigh and foot section goes to a Psoas-like position.

If the control unit's DOWN button is activated, the thigh and foot section goes first to the level position and then into the so-called heart position (the foot section below the bed level).



8.6 Blocking function (option)

⚠ If there is a risk of incorrect use, the bed can be equipped with a blocking function (accessory).

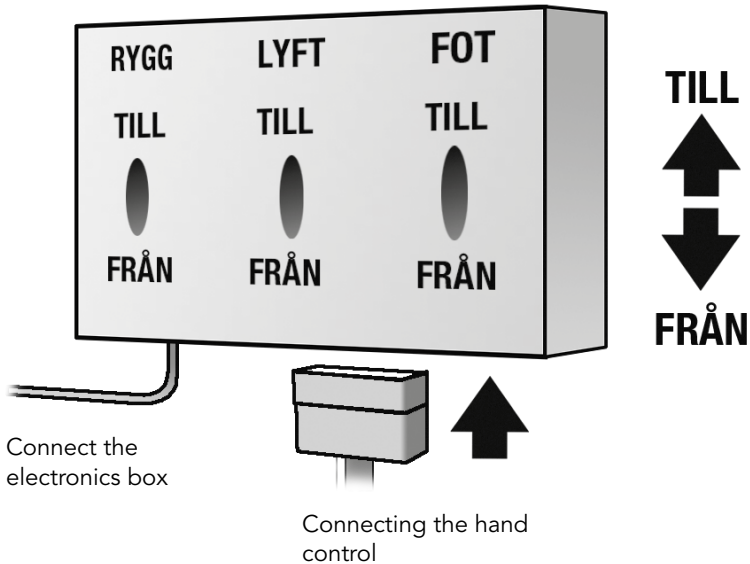

8.7 Using the lifting pole

⚠ The lifting pole may only be loaded when it is properly mounted and when the handle is in the middle of the bed.



9. Accessories

The QVINTETT Hospital Bed can be equipped with many accessories to make life easier for users as well as carers.



Grab rail SV 45



Grab rail Assist



Bed table Qlassic



Lifting pole including handle



Integrated bed rails,



Battery backup CS1

Other accessories, see website: www.comfortsystem.se

 Comfort System's accessories program, together with the bed, meet the bed standard EN 1970. Comfort System CANNOT accept product liability if other accessories are used on the bed without Comfort System's approval.



10. Technical Specifications

10.1 Technical Specifications to 80 cm wide bed

DIMENSIONS

Bed frame Safir 3-60

Total external size, length, cm 214

Total external size, width, cm 102

Total internal size, length, cm 206

Sprung base

Divided into 4 parts

Backrest 77 cm

Seat section 20 cm

Thigh section 37 cm

Foot section 56 cm

Max mattress size 80x200

Rec. mattress size 75x200

Can be lengthened in steps of 5 cm to max internal size 221 cm

NOTE! For extensions over 210 cm, a special sprung base extender is required (customization).



In addition to scheduling can mesh base, continuously and individually adjusted by means of electric motors as described above. All settings are made with the bed's control box.

WEIGHT for sprung base model A-80-CS2

Sprung base 46 kg

(excl. thigh/foot section)

Thigh/foot section (removable) 9 kg

Total weight 55 kg

CAPACITY BED LIFT

Wheel lock

Model B-CS2

C lock

Model C-CS2

C lock

Model E-CS2

I lock

Wheel diameter, standard

100 mm

100 mm

125 mm

Alternative wheel diameter

50, 80 mm

50, 80 mm

50, 80, 100 mm

Clearance

ca 11-16 cm

ca 11-16 cm

ca 7-15 cm

Weight

43 kg

49 kg

40 kg

Sprung base A-80-CS2 can be chosen with bed lift type B/C/E-CS2

CAPACITY COMPLETE BED (regardless of sprung base)

with bed lift

Lowest height *

Model B-CS2

ca 29-34 cm

Model C-CS2

ca 29-34 cm

Model E-CS2

ca 25-33 cm

Highest height *

ca 79-84 cm

ca 77-82 cm

ca 75-83 cm

SWL (Safety working load)

200 kg

235 kg

200 kg

User weight

165 kg

200 kg

165 kg

*) Size given excl. mattress.

All rights reserved, for current information see our website: www.comfortsystem.se



10.2 Technical Specifications to 90 cm wide bed

DIMENSIONS

Bed frame Safir 3-60

Total external size, length, cm 214
 Total external size, width, cm 102
 Total internal size, length, cm 206

Sprung base

Divided into	4 parts
Backrest	77 cm
Seat section	20 cm
Thigh section	37 cm
Foot section	56 cm
Max mattress size	90x200
Rec. mattress size	85x200
Can be lengthened in steps of 5 cm to max internal size	221 cm

NOTE! For extensions over 210 cm, a special sprung base extender is required (customization).



In addition to scheduling can mesh base, continuously and individually adjusted by means of electric motors as described above. All settings are made with the bed's control box.

WEIGHT for sprung base model A-90-CS2

Sprung base (excl. thigh/foot section)	46 kg
Thigh/foot section (removable)	9 kg
Total weight	55 kg

WEIGHT for sprung base model H-90-CS2

Sprung base – back frame	24 kg
Sprung base – foot frame	22 kg
Thigh/foot section (removable)	9 kg
Total weight	55 kg

CAPACITY BED LIFT

Wheel lock
 Wheel diameter, standard
 Alternative wheel diameter
 Clearance
 Weight

Model B-CS2

C lock
 100 mm
 50, 80 mm
 ca 11-16 cm
 43 kg

Model C-CS2

C lock
 100 mm
 50, 80 mm
 ca 11-16 cm
 49 kg

Model E-CS2

I lock
 125 mm
 50, 80, 100 mm
 ca 7-15 cm
 40 kg

Sprung base A/H-90-CS2 can be chosen with bed lift type B/C/E-CS2

CAPACITY COMPLETE BED (regardless of sprung base)

with bed lift

Lowest height *
 Highest height *
 SWL (Safety working load)
 User weight
 *) Size given excl. mattress.

Model B-CS2

ca 29-34 cm
 ca 79-84 cm
 200 kg
 165 kg

Model C-CS2

ca 29-34 cm
 ca 77-82 cm
 235 kg
 200 kg

Model E-CS2

ca 25-33 cm
 ca 75-83 cm
 200 kg
 165 kg

All rights reserved, for current information see our website: www.comfortsystem.se



10.3 Technical Specifications to 105 cm wide bed

DIMENSIONS

Bed frame Safir 3-60

Total external size, length, cm 214

Total external size, width, cm 117

Total internal size, length, cm 206

Sprung base

Divided into 4 parts

Backrest 77 cm

Seat section 20 cm

Thigh section 37 cm

Foot section 56 cm

Max mattress size 105x200

Rec. mattress size 100x200

Can be lengthened in steps of 5 cm to max internal size 221 cm

NOTE! For extensions over 210 cm, a special sprung base extender is required (customization).

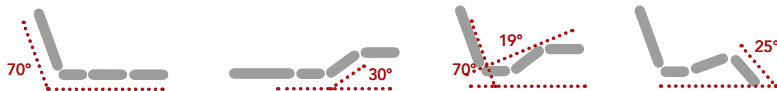

In addition to scheduling can mesh base, continuously and individually adjusted by means of electric motors as described above. All settings are made with the bed's control box.

WEIGHT for sprung base

model H-105-CS2

Sprung base – back frame 28 kg

Sprung base – foot frame 22 kg

Thigh/foot section (removable) 11 kg

Total weight 61 kg

CAPACITY BED LIFT

Wheel lock

Wheel diameter, standard

Alternative wheel diameter

Clearance

Weight

Model L-CS2

C lock

100 mm

50, 80 mm

ca 11-16 cm

56 kg

Sprung base H-105-CS2 can be chosen with bed lift model L-CS2

CAPACITY COMPLETE BED (regardless of sprung base)

with bed lift

Lowest height *

Highest height *

SWL (Safety working load)

User weight

*) Size given excl. mattress.

Model L-CS2

ca 29-34 cm

ca 77-82 cm

220 kg

185 kg

All rights reserved, for current information see our website: www.comfortsystem.se



10.4 Technical Specifications to 120 cm wide bed

DIMENSIONS

Bed frame Safir 3-60

Total external size, length, cm 219
 Total external size, width, cm 132
 Total internal size, length, cm 211

Sprung base

Divided into	4 parts
Backrest	77 cm
Seat section	20 cm
Thigh section	37 cm
Foot section	56 cm
Max mattress size	120x200
Rec. mattress size	115x200
Can be lengthened in steps of 5 cm to max internal size	221 cm

NOTE! For extensions over 210 cm, a special sprung base extender is required (customization).



In addition to scheduling can mesh base, continuously and individually adjusted by means of electric motors as described above. All settings are made with the bed's control box.

WEIGHT for sprung base

model H-120-CS2

Sprung base – back frame	33 kg
Sprung base – foot frame	25 kg
Thigh/foot section (removable)	12 kg
Total weight	70 kg

CAPACITY BED LIFT

Wheel lock	C lock
Wheel diameter, standard	100 mm
Alternative wheel diameter	50, 80 mm
Clearance	ca 11-16 cm
Weight	56 kg

Model L-CS2

Sprung base H-120-CS2 can be chosen with bed lift model L-CS2

CAPACITY COMPLETE BED (regardless of sprung base)

with bed lift

Lowest height *	ca 29-34 cm
Highest height *	ca 77-82 cm
SWL (Safety working load)	220 kg
User weight	185 kg

Model L-CS2

*) Size given excl. mattress.

All rights reserved, for current information see our website: www.comfortsystem.se



11. Environment, Transport and Storage

11.1 Environment

Comfort System wants to work for an improved environment in the future. Among other things, we have developed a method for packaging beds that has reduced our transport needs by approx. 30 %! Naturally, we are certified according to ISO 14001.



Our products are recyclable. Help our environment and hand in the product for recycling.

11.2 Transport and storage

Our method for packing means that it only takes up approx. 1 m² to store four beds!

Conditions for transport and storage:

- Air humidity between 10 and 80% RH
- Temperature between -30° and 40°C
- Pressure between 700 and 1100 hPa

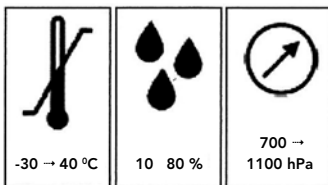



12. Maintenance and reconditioning

The bed is designed to require the minimum maintenance. It is recommended that preventive maintenance be carried out according to our service schedule every other year.

12.1 Normal Cleaning

- Mechanics and motor systems are cleaned with a damp cloth. Readily available cleansers and disinfectants can be used. Can be rinsed with spray water.
 - The bed ends and long sides are cleaned with a damp cloth. Readily available cleansers and disinfectants can be used.
-

12.2 High-pressure wash

 Beds manufactured after March 2004 can also be high-pressure washed.

Before washing:

- Motors have to be in the bottom position
 - Lift out the electronics unit (see Assembly instructions)
-

12.3 Inspection in the case of reconditioning

- Check that the attachment points for all motors are undamaged and do not have unnaturally large gaps.
- Check that there isn't any visible damage on the motors and mechanics.
- Check that joints and fasteners for the back and leg sections are undamaged and do not have unnaturally large gaps.
- Check that joints and fasteners for the bed lift's scissor section are undamaged and do not have an unnaturally large gap.
- Check that the bed lift's wheels are firmly tightened.
- Tighten the screws for bed ends and long sides.
- Check that the mains cable and cable to the control unit are undamaged.
- Re-lubricate if necessary according to inspection report.



12.4 Regular inspection

- It is recommended that inspection takes place according to point 12.3 every other year.

12.5 Lubrication points / reconditioning

The sprung base's jointed points do not normally need lubricating.

If the bed lift is cleaned with substantial rinsing or high-pressure wash.

Re-lubricate if necessary according to inspection report.

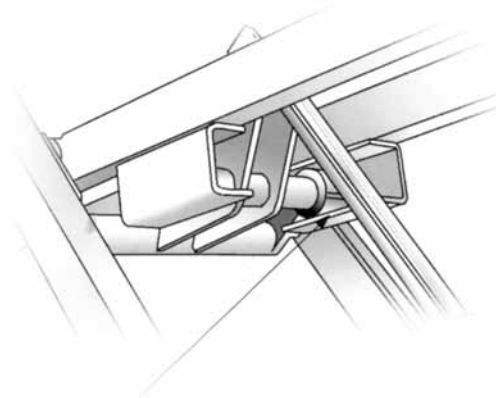
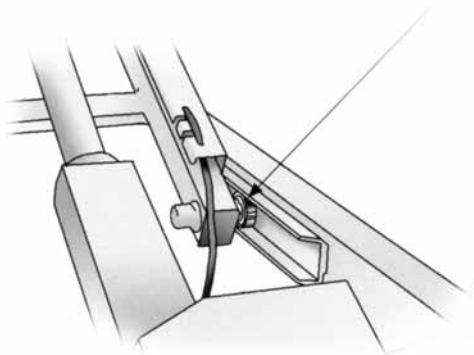



13. Troubleshooting schedule

NOTE! Check that the bed is connected to a wall socket and that the green light is shining on the electronics box.

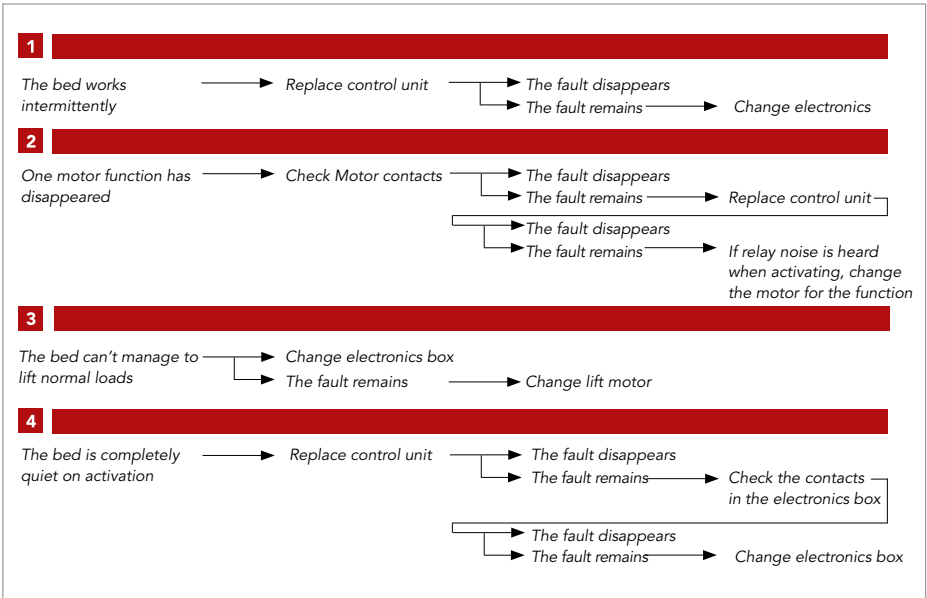

If you have any questions, please contact us:

Comfort System Scandinavia AB

Box 4034, Vistakullevägen 18
561 04 HUSKVARNA, Sweden
Tfn +46 (0)36 51590
Fax +46 (0)36 50001
info@comfortsystem.se
www.comfortsystem.se



14. Maintenance Schedule

Maintenance Schedule for example, inspection, service, warranty exchange, etc.

Action	Date	Sign

Our experience - your guarantee

Since its start in 1987, Comfort System has kept more or less the same ownership and has operated under the same name – a fact that is almost unique today in the branch. Our long experience and knowledge of our product assortment, means that as a customer you can feel secure in your choice of supplier.



15. Inspection report

Inspection reports and lubrication schedule for the care bed Quintett

For increased safety, reduced wear and higher performance, follow points 1.1 – 5.3. In these instructions, a number of points have been given the symbol 1 or 2. This is a reminder about lubrication.

 = lubricate with Prime.



 = lubricate with lithium grease.

After lubricating, wipe away all excess grease.

Take great care, be careful to avoid spilling lubricants on to the floor and the surroundings.







Lubricant spills on floors are a major safety hazard "risk of slipping".

INSPECTION POINTS:

	Satis factory	Action to be taken	Action taken	Lubrication carried out
1 ELECTRONICS				
1.1 Cable from wall socket and contact are undamaged.....	<input type="checkbox"/>	<input type="checkbox"/>	<input type="checkbox"/>	
1.2 Green control light shines	<input type="checkbox"/>	<input type="checkbox"/>	<input type="checkbox"/>	
1.3 Cables and plugs are undamaged and correctly connected:				
1.3.1 Back motor	<input type="checkbox"/>	<input type="checkbox"/>	<input type="checkbox"/>	
1.3.2 Foot motor	<input type="checkbox"/>	<input type="checkbox"/>	<input type="checkbox"/>	
1.3.3 Lift motor.....	<input type="checkbox"/>	<input type="checkbox"/>	<input type="checkbox"/>	
1.2.4 Control unit.....	<input type="checkbox"/>	<input type="checkbox"/>	<input type="checkbox"/>	
1.3.5 Connected battery compartment, where applicable	<input type="checkbox"/>	<input type="checkbox"/>	<input type="checkbox"/>	
2 BED LIFT				
2.1 The bed lift's work area, approx. 50 cm	<input type="checkbox"/>	<input type="checkbox"/>	<input type="checkbox"/>	
2.2 Visible damage on lift mechanics.....	<input type="checkbox"/>	<input type="checkbox"/>	<input type="checkbox"/>	
2.3 Damage or unnaturally large gaps in fasteners and joints.....	<input type="checkbox"/>	<input type="checkbox"/>	<input type="checkbox"/>	
2.4 Bearings and bearing races. Clean up lubricant on new		<input type="checkbox"/>	<input type="checkbox"/>	<input type="checkbox"/>
2.5 The lift motor's attachment points, cotter pins and locking rings fit properly and are secured.....		<input type="checkbox"/>	<input type="checkbox"/>	<input type="checkbox"/>
2.6 Visible external damage on lift motor.....	<input type="checkbox"/>	<input type="checkbox"/>	<input type="checkbox"/>	
2.7 Casters or Central Locking	<input type="checkbox"/>	<input type="checkbox"/>	<input type="checkbox"/>	



INSPECTION POINTS:

	Satis factory	Action to be taken	Action taken	Lubrication carried out
3 SPRUNG BASE				
3.1 Visible damage on the sprung base's mechanics.....	<input type="checkbox"/>	<input type="checkbox"/>	<input type="checkbox"/>	
3.2 The fasteners for back and thigh section are undamaged and do not have unnaturally large gaps..... 	<input type="checkbox"/>	<input type="checkbox"/>	<input type="checkbox"/>	<input type="checkbox"/>
3.3 The back section goes up to approx. 75 degrees.....	<input type="checkbox"/>	<input type="checkbox"/>	<input type="checkbox"/>	
3.4 The plastic hinge in the back section is undamaged and cotter pin/locking ring are intact. Pull apart and lubricate bearing surfaces and cotter pins..... 	<input type="checkbox"/>	<input type="checkbox"/>	<input type="checkbox"/>	<input type="checkbox"/>
3.5 Wooden slats and fasteners are undamaged and the wooden slats are sitting in place	<input type="checkbox"/>	<input type="checkbox"/>	<input type="checkbox"/>	
3.6 Visible damage on back motor	<input type="checkbox"/>	<input type="checkbox"/>	<input type="checkbox"/>	
3.7 The attachment point for the back motor is undamaged and does not have an unnaturally large gap	<input type="checkbox"/>	<input type="checkbox"/>	<input type="checkbox"/>	
3.8 The back motor's cotter pins are in place properly and are secured. 	<input type="checkbox"/>	<input type="checkbox"/>	<input type="checkbox"/>	<input type="checkbox"/>
3.9 The foot section goes up to the high position	<input type="checkbox"/>	<input type="checkbox"/>	<input type="checkbox"/>	
3.10 The foot section goes down to the heart position	<input type="checkbox"/>	<input type="checkbox"/>	<input type="checkbox"/>	
3.11 The plastic hinge in the thigh/foot section is undamaged and cotter pin/locking ring are intact. 	<input type="checkbox"/>	<input type="checkbox"/>	<input type="checkbox"/>	<input type="checkbox"/>
3.12 Visible damage on the foot motor	<input type="checkbox"/>	<input type="checkbox"/>	<input type="checkbox"/>	
3.13 The attachment point for the foot motor is undamaged and does not have an unnaturally large gap	<input type="checkbox"/>	<input type="checkbox"/>	<input type="checkbox"/>	
3.14 The foot motor's cotter pins are in place properly and are secured. 	<input type="checkbox"/>	<input type="checkbox"/>	<input type="checkbox"/>	<input type="checkbox"/>
4 BED RAILS				
4.1 Visible damage on the bed rails.....	<input type="checkbox"/>	<input type="checkbox"/>	<input type="checkbox"/>	
4.2 The bed rails run easily.....	<input type="checkbox"/>	<input type="checkbox"/>	<input type="checkbox"/>	
4.3 The bed rails lock properly.....	<input type="checkbox"/>	<input type="checkbox"/>	<input type="checkbox"/>	
5 BED FRAME				
For bed frames with integrated bed rails				
5.1 Tighten the screws holding the bed ends Note! Screws in the bed rails must NOT be touched..... 	<input type="checkbox"/>	<input type="checkbox"/>	<input type="checkbox"/>	
5.2 The track in which the bed rails run. Spray all surfaces in the track. 	<input type="checkbox"/>	<input type="checkbox"/>	<input type="checkbox"/>	<input type="checkbox"/>
Gällar övriga sängramar				
5.3 Tighten all screws holding bed ends and long sides	<input type="checkbox"/>	<input type="checkbox"/>	<input type="checkbox"/>	



16. Delivery control

DOT	CONTROL SOLUTION	APPROVED
1	Fixings lift motor controlled	<input type="checkbox"/>
2	Test driving beds lifting and controlled work area.....	<input type="checkbox"/>
3	Moving parts in the bed lift lubrication by schedule.....	<input type="checkbox"/>
4	Fixing the bed lift (snap fasteners)	<input type="checkbox"/>
5	Test driving back and leg function	<input type="checkbox"/>
	- motor noise level	
	- function	
6	Control of back function	<input type="checkbox"/>
	- lift arms correctly installed and secured	
	- lead correctly secured	
7	Control of all lead in bone function	<input type="checkbox"/>
	- lift arms correctly installed and secured	
	- lead correctly secured	
8	Checking the adjustable end (sample)	<input type="checkbox"/>
	- length setting	
9	Check engine mounts	<input type="checkbox"/>
	- including securing pins	
	- visual inspection of welds	
10	Control of angle - dividing panel (sample).....	<input type="checkbox"/>
11	Visual inspection	<input type="checkbox"/>
	- surface treatment and welding seams	

Serial BED LIFT	SIGN	DATUM
------------------------	------	-------

Serial BED BOTTOM	SIGN	DATUM
--------------------------	------	-------



ComfortSystem
– our experience is your guarantee